

# **Firestone UltraPly™ TPO**

## **The light colored roofing choice**



TPO Roofing Systems

**Firestone**  
**BUILDING PRODUCTS**  
**NOBODY COVERS YOU BETTER.®**



## Firestone UltraPly TPO roofing systems

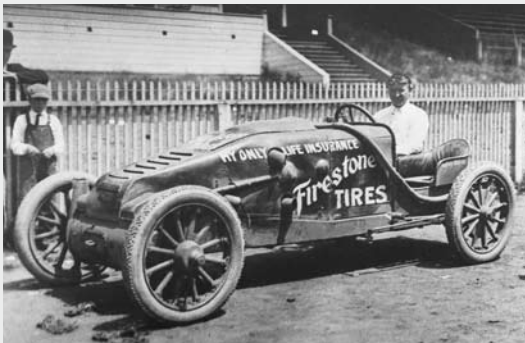

### **Firestone: over a century of experience**

Firestone Building Products entered the commercial roofing industry in 1980, building upon a 100-year-plus heritage of success and innovation in rubber polymer technology. Today, the company has grown into a world class manufacturer of quality commercial roofing systems. Firestone is committed to offer a complete line of high performing roofing solutions as individual as your building. This commitment has resulted in the development of Firestone's UltraPly TPO Roofing Systems.

### **Ultraply TPO: the light colored roofing choice**

Firestone UltraPly TPO is the smart choice when seeking a light colored, environmentally friendly roofing system that combines aesthetics with strong resistance to ultraviolet radiation, weathering, and outstanding seam strength. UltraPly TPO is a proprietary thermoplastic polyolefin combining polypropylene and ethylene propylene rubber. The scrim-reinforced membrane combines the weatherability of rubber with the heat weldability of a thermoplastic in a flexible sheet with excellent layflat characteristics.



# The unique benefits of UltraPly TPO

Firestone UltraPly TPO Roofing Systems offer a unique combination of features and benefits which have been demonstrated on rooftops around the world.

## ✓ Ease of application

Firestone UltraPly TPO is available in widths up to 3.05 m providing fast, economical coverage. At 1.13 kg/m<sup>2</sup> it is a lightweight membrane offering a variety of installation options for low slope roofing applications in both refurbishment and new construction projects.

## ✓ Hot air welded seams

Firestone UltraPly TPO hot-air welded seams result in fast, economical installation, consistent seam quality and high strength. Heat welded seams form a homogeneous bond by fusing the top and bottom sheets together. UltraPly TPO's seaming process enables it to be installed year-round in a variety of weather conditions.

## ✓ Superior weatherability and durability

Firestone UltraPly TPO membrane contains no plasticizers and no halogen flame retardants resulting in outstanding resistance to UV radiation and ozone. The membrane also exhibits strong resistance to algae and fungi growth and common rooftop chemicals.

## ✓ Outstanding reflectivity

Firestone UltraPly TPO's light colored surface reflects sunlight before it can be absorbed and converted into heat energy, eventually improving the energy efficiency of the building.

## ✓ Color

The standard colors for Firestone UltraPly TPO membrane are white and grey.



## Firestone UltraPly TPO – Product Information

Product Line			
Membrane	EU Sizes	US Sizes	Unit
Thickness	1.2 / 1.5 / 1.8	1.1 / 1.5	mm
Width	1.5 – 2.0	1.52 – 2.44 – 3.05	m
Length	30.5	30.5	m
Weight	1.13 / 1.53 / 1.70	1.13 / 1.53	kg/m <sup>2</sup>
Physical Properties			
Property	Test Method	Typical Value	Unit
Watertightness	EN 1928 (B)	pass	
Tensile strength (both directions)	EN 12311-2 (A)	≥ 800	MPa
Elongation	EN 12311-2 (A)	≥ 20	%
Resistance to static loading (EPS & concrete)	EN 12730 (B)	≥ 25	kg
Resistance to impact (EPS & concrete)	EN 12691	≥ 10	mm
Tear resistance L / T	EN 12310-2	≥ 400 / 400	N
Joint peel resistance	EN 12316-2	≥ 100	N/50mm
Joint shear resistance	EN 12317-2	≥ 800	N/50mm
UV exposure	EN 1297	pass	
Foldability at low temperature	EN 495-5	≤ -45	°C
External fire performance	EN 13501-5	B <sub>ROOF</sub> (t1)	
Reaction to fire	EN 13501-1	E	
Root resistance	prEN 13948	pass	

For latest updates and additional info please consult our website at [www.firestonebpe.com](http://www.firestonebpe.com). Testing results and/or copies of Approval Documents for above mentioned membranes are available upon request.

# Because the environment matters

Firestone Building Products is committed to operate in an environmentally responsible manner. An environmental management system, which complies with the ISO 14001 requirements, has been implemented throughout the company's manufacturing facilities. This certification is a testimony of the company's environmental awareness.



## Eco-friendly membrane

Firestone UltraPly TPO is a heat reflective and energy efficient roofing membrane. The membrane's chlorine-free, non-halogenated and plasticizer-free formulation in combination with the hot-air welded seaming method further contribute to the care for the environment.

The TPO membrane can also be easily recycled. These ecological benefits make Firestone UltraPly TPO an environmentally friendly roofing solution.

## Green Roof System

Due to ever increasing concern for the environment, green roofs are becoming regular part of our landscape. Firestone UltraPly TPO has successfully passed the FLL test for root penetration resistance in green roofs. It is an ideal membrane for combination with extensive green roof systems using lightweight and low maintenance sedum vegetation.

The ecological benefits of a green roof system are numerous:

- **Reduction of the urban heat island effect**  
Green roofs prevent reflection of the heat into the surrounding atmosphere. In addition, the plants on green roofs transpire resulting in cooling the atmosphere around them.
- **Reduction of energy costs**  
Green roofs offer excellent insulation properties and help to keep the cold out in winter and the heat out in summer.
- **Storm water management**  
Green roofs are an excellent source control technique in storm-water management through water retention and increased evaporation.
- **New habitats for plants & animals**  
Green roofs create a natural habitat for local wildlife and plants.
- **Improved air quality**  
Green roofs help to purify the air by filtering dusts and pollutants and converting CO<sub>2</sub> into oxygen.
- **Reduction of noise pollution**  
Green roofs serve as excellent sound insulators reducing the noise pollution from outside the building.

# Reliable solutions for every need

UltraPly's lightweight, flexible, scrim-reinforced membrane is engineered to provide dependable performance in most commercial roofing applications. Firestone is offering a variety of installation options to meet the most demanding rooftop challenges for both renovation and new built applications.

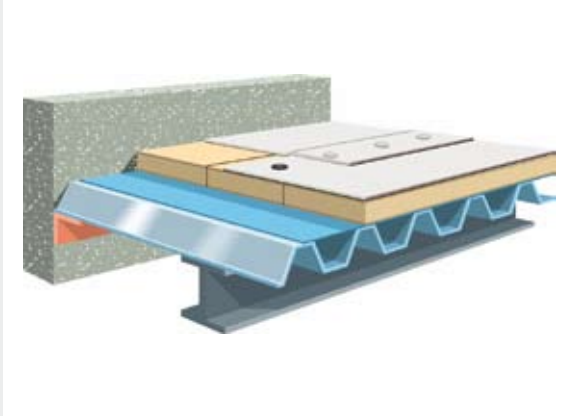

## **Firestone TPO Mechanically Attached System**

The Firestone TPO Mechanically Attached System uses sheets up to 2.44 m wide. The width of the sheet used and the fastening pattern differs to accommodate specific wind loadings. Adjoining sheets are overlapped at least 150 mm. The sheets are attached in the overlap using approved plates and fasteners placed approx. 50 mm in from the inside panel edge. Side laps between adjoining sheets are overlapped a minimum of 75 mm. Panels are heat-welded using heat-welding equipment according to the Firestone specifications. Roof perimeters and penetrations are flashed in accordance with Firestone specifications.

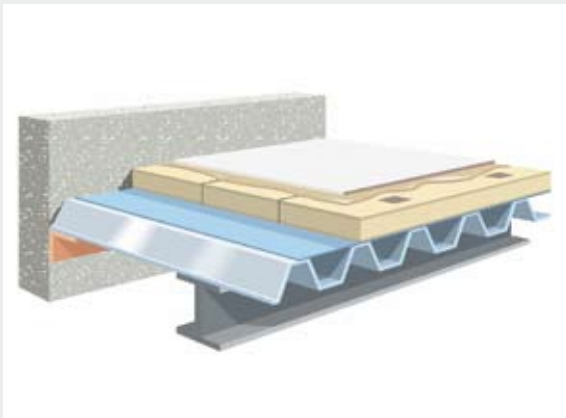

## **Firestone TPO Fully Adhered System**

In the Firestone TPO Fully Adhered System, the TPO sheets are fully adhered directly to an acceptable substrate using contact adhesive. Adjoining sheets are overlapped at least 75 mm and heat-welded. Roof perimeters and penetrations are flashed in accordance with Firestone specifications. The Fully Adhered System can be applied on any building where the roof deck is compatible with the insulation fastening system and will provide sufficient pull-out resistance. The insulation used must be compatible with the Firestone contact adhesives.

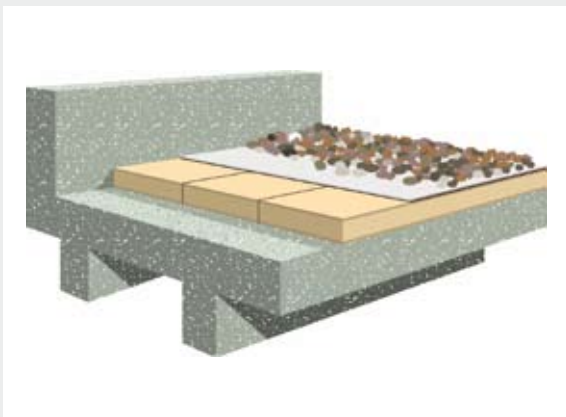

## **Firestone TPO Ballasted System**

In the Firestone TPO Ballasted System, the TPO sheets are loose laid over an acceptable substrate. Adjoining sheets are overlapped at least 75 mm and heat-welded. Roof perimeters and penetrations are flashed in accordance with Firestone specifications. Once completed, the TPO membrane is held in place using approved river washed gravel or smooth paving stones, with a minimum weight of 50 kg/m<sup>2</sup>. The Ballasted System can be applied on any building that can accommodate the extra load of the ballast and where the roof slope does not exceed 1:6.

# A complete range of accessories

Firestone has developed a complete range of accessories for its UltraPly TPO Roofing Systems to meet the requirements of various roofing applications and installation details. This offers building owners and specifiers the convenience to obtain all components necessary for a complete TPO Roofing System from Firestone Building Products.



## Flashings

**Firestone UltraPly TPO Inside/Outside Molded Corners** are made from non-reinforced thermoplastic polyolefin membrane and used for flashing inside and outside corners and as square tube flashing.

**Firestone UltraPly TPO Molded Pipe Boots** are made from non-reinforced thermoplastic polyolefin membrane and used for flashing round penetrations.

**Firestone UltraPly TPO T-joint Covers** are made from non-reinforced thermoplastic polyolefin membrane and used to seal all T-joints at seam intersections.

**Firestone UltraPly TPO Unsupported Flashing** is made from non-reinforced thermoplastic polyolefin membrane and is used where pre-molded accessories are not appropriate.

## Adhesives and cleaning agents

**Firestone UltraPly TPO Bonding Adhesive** is a solvent based contact adhesive for bonding TPO to wood, metal, masonry and other acceptable substrates.

**Firestone Clear Splice Wash** is designed to clean and prepare contaminated TPO membrane.

## Sealants

**Firestone UltraPly TPO Cut Edge Sealant** is a polymer-based sealant used to seal all cut edges of Firestone UltraPly TPO membrane.

**Firestone Pourable Sealant** is a two-part polyurethane sealer used to fill and seal penetration pockets.

**Firestone Water Block Sealant** is a butyl-based sealant used for watertight seals when applied under compression.

**Firestone General Purpose Sealant** is a white high quality sealant used to seal all cut edges of Firestone UltraPly TPO membrane and as a general purpose sealant.

## Fasteners, plates and other accessories

**Firestone Fasteners** (various) are used to mechanically secure HD seam plates, termination bars and/or insulation boards to the substrate.

**Firestone HD Seam Plates** are 60 mm wide galvanized steel plates used for anchoring UltraPly TPO membrane.

**Firestone Termination Bar** is an extruded aluminum profile to attach and seal flashing terminations e.g. parapets and upstands.

**Firestone TPO Eco Walkway Pad** is composed of recycled EPDM and TPO and used as a protection of TPO membranes in areas of regular traffic.

**Firestone TPO Coated Metal** is made from a flexible non-reinforced TPO membrane factory laminated to galvanized steel used as a flashing component.

# Firestone: a quality tradition

At Firestone, the definition of quality is continuous improvement and meeting the customer's needs and expectations for products that perform.

## Research and development

In order to ensure a superior product even before the manufacturing process, each component of Firestone's UltraPly TPO Roofing Systems is designed and tested by skilled engineers and chemists in the company's R&D Department.

## Quality manufacturing

Firestone Building Products has installed state-of-the-art equipment at each of its plants. From raw materials selection through manufacturing to finished product testing, Firestone Building Products follows stringent quality control guidelines. The company's TPO manufacturing facility has received **ISO 9001** certification for its quality management system and **ISO 14001** certification for its environmental management system.

Firestone UltraPly TPO membranes have obtained the **European CE-mark**, proving that these products and associated production methods are meeting today's requirements in terms of mechanical resistance and stability, safety in case of fire, hygiene, health and environmental protection, safety in use, protection against noise, energy economy and heat retention, aspects of durability, serviceability and identification.

## Quality installation

Firestone UltraPly TPO Roofing Systems are installed by professional and trained Firestone Licensed Roofing Contractors who share our commitment to quality roof installations.

## Field support services

Firestone's support and training extends onto the roof. Our field technicians provide professional assistance at job start-up, make installation inspections and offer on-site training to the roofing crew.

## Code approvals

UltraPly TPO meets a variety of model building code approvals and classifications, depending on the specific system or assembly. It holds a European Technical Approval (ETA) according to the ETAG006 code for mechanically fixed roof waterproofing systems. Firestone UltraPly TPO Roofing Systems have obtained a  $B_{ROOF}(t1)$  fire resistance rating when tested according to EN 1187-1 and are also approved for use in Factory Mutual (FM) constructions.



**Firestone Building Products**

Ikaroslaan 75 | 1930 Zaventem | Belgium

Phone +32(0)2 711 44 50 | Fax +32(0)2 721 27 18

info@fbpe.be | www.firestonebpe.com

| YOUR LOCAL CONTACT |

**Firestone**  
**BUILDING PRODUCTS**  
**NOBODY COVERS YOU BETTER.®**